

# MAXIM

## MAX5035 Evaluation Kit

**Evaluates: MAX5035**

### General Description

The MAX5035 evaluation kit (EV kit) is a fully assembled and tested surface-mount printed circuit board (PCB) that contains a step-down DC-DC switching-regulator circuit. The circuit utilizes a MAX5035 adjustable converter configured for a 5V output and provides up to 1A of current. The converter operates from a wide input range of 8V to 76V.

The MAX5035 MAXPower IC features a built-in high-side switch and an automatic pulse-skipping mode operation. The MAX5035 EV kit demonstrates low quiescent current and high efficiency up to 92%. The MAX5035 MAXPower IC switches at 125kHz.

**Warning:** The MAX5035 EV kit is designed to operate with high voltages. Dangerous voltages are present on this EV kit and on equipment connected to it. Users who power up this EV kit or power the sources connected to it must be careful to follow appropriate safety procedures when working with high-voltage electrical equipment.

Under severe fault or failure conditions, this EV kit may dissipate large amounts of power, which could result in the mechanical ejection of a component or of component debris at high velocity. Operate this EV kit with care to avoid possible personal injury.

### Features

- ◆ 8V to 76V Input Voltage Range
- ◆ 5V Output at Up to 1A
- ◆ 92% Efficiency
- ◆ Adjustable Output Voltage Through Resistive Voltage-Divider
- ◆ No Load Quiescent Current:
  - 794 $\mu$ A at  $V_{IN} = 76V$
  - 582 $\mu$ A at  $V_{IN} = 42V$
  - 392 $\mu$ A at  $V_{IN} = 12V$
- ◆ 125kHz Switching Frequency
- ◆ Automatic Pulse-Skipping Mode
- ◆ Fully Assembled and Tested

### Ordering Information

PART	TEMP RANGE	IC-PACKAGE
MAX5035EVKIT	0°C to +70°C	8 SO

### Component List

DESIGNATION	QTY	DESCRIPTION
C1	1	68 $\mu$ F $\pm$ 20%, 100V electrolytic capacitor (12.5 x 13.5) Panasonic EEFVK2A680Q
C2	1	68 $\mu$ F $\pm$ 20%, 10V tantalum capacitor (C) AVX TPSD686M010R0100 (0.100 ESR) or Vishay 594D686X0010C2T (0.1 ESR)
C3, C4	2	0.1 $\mu$ F $\pm$ 10%, 50V X7R ceramic capacitors (0603) TDK C1608X7R1H104K
C5	0	Not installed, capacitor (0805)
C6	1	0.2 $\mu$ F $\pm$ 10%, 100V X7R ceramic capacitor (1206) AVX 12061C224KAZ

DESIGNATION	QTY	DESCRIPTION
D1	1	80V, 5A Schottky diode (D0-204AR) International Rectifier 50SQ080
L1	1	100 $\mu$ H, 1.8A inductor Coilcraft, Inc. DO5022P-104
R1	1	41.2k $\Omega$ $\pm$ 1% resistor (0805)
R2	1	13.3k $\Omega$ $\pm$ 1% resistor (0805)
R3	1	130k $\Omega$ $\pm$ 1% resistor (0805)
R4	0	Not installed, resistor (0805)
R5	1	45.3k $\Omega$ $\pm$ 1% resistor (0603)
U1	1	MAX5035DUSA (8-pin SO)
JU1	1	3-pin header
—	1	Shunt (JU1)
—	1	PCB: MAX5035 evaluation kit

# MAX5035 Evaluation Kit

## Component Suppliers

SUPPLIER	PHONE	FAX	WEBSITE
AVX Corp.	843-946-0238	843-626-3123	www.avxcorp.com
Coilcraft, Inc.	847-639-6400	847-639-1469	www.coilcraft.com
International Rectifier	310-322-3331	310-726-8721	www.irf.com
Panasonic Corp.	714-373-7366	714-737-7323	www.panasonic.com
TDK Corp.	847-803-6100	847-390-4405	www.component.tdk.com
Vishay	402-563-6866	402-563-6296	www.vishay.com

**Note:** Indicate that you are using the MAX5035 when contacting these component suppliers.

### Quick Start

The MAX5035 EV kit is fully assembled and tested. Follow these steps to verify board operation. **Do not turn on the power supply until all connections are completed.**

#### 5V Output Verification

- 1) Verify that a shunt is across pins 1 and 2 of jumper JU1 (SHDN).
- 2) Connect a voltmeter to the VOUT pad and GND pad.
- 3) Connect a 12V DC power supply to the VIN pad. Connect the supply ground to the GND pad.
- 4) Turn on the power supply and verify that VOUT is at 5V.

For instructions on selecting the feedback resistors for other output voltages, see the *Evaluating Other Output Voltages* section.

### Detailed Description

The MAX5035 EV kit features a 5W step-down DC-DC switching-regulator circuit. The circuit uses a MAX5035 adjustable output-voltage converter to provide an output voltage of 5V and can deliver up to 1A of current to the output. The user must provide an 8V to 76V DC source that is capable of supplying at least 2A of current to power the circuit.

The MAX5035 converter's built-in, high-side, low on-resistance DMOS transistor reduces component count while maximizing efficiency. Under light loads (approx-

mately 85mA) the MAX5035 operates in pulse-skipping mode, and under heavy loads it automatically enters PWM mode. The circuit switches at 125kHz.

The EV kit features a PCB pad for the  $\overline{\text{SHDN}}$  signal to interface with an external controller. Startup delays can be evaluated by installing resistor R4 and capacitor C5.

### Jumper Selection

#### Shutdown Mode

The MAX5035 EV kit features a shutdown mode that reduces the MAX5035 quiescent current to 10 $\mu$ A (typ), thus reducing the power drain during shutdown mode. The 3-pin jumper, JU1, selects the shutdown mode for the MAX5035 EV kit. Table 1 lists the selectable jumper options.

**Table 1. Jumper JU1 Functions**

SHUNT LOCATION	$\overline{\text{SHDN}}$ PIN	MAX5035 EV KIT OUTPUT
1 and 2	Connected to VIN through R3	MAX5035 enabled
2 and 3	Connected to GND	MAX5035 disabled
None	External controller connected to $\overline{\text{SHDN}}$ pad	Logic high = enabled, Logic low = disabled

**Caution:** Do not connect an external controller to the  $\overline{\text{SHDN}}$  pad while a shunt is on jumper JU1 since the external controller may be damaged.

# MAX5035 Evaluation Kit

Evaluates: MAX5035

## Evaluating Other Output Voltages

The MAX5035 step-down DC-DC switching regulator output is set to 5V by feedback resistors R1 and R2. To generate output voltages other than 5V (1.25V to 12V), select different external voltage-divider resistors for R1 and R2. Refer to the *Setting the Output Voltage* section in the MAX5035 data sheet for instructions on selecting the resistors. The minimum input voltage for a given output voltage is maximum duty-cycle dependent for that input voltage. Refer to the MAX5035 data sheet for additional information.

## Startup Delays/ Sequencing Two DC-DC Converters

The MAX5035 EV kit can be configured for various startup delays. To evaluate a startup delay, cut open the PCB trace shorting resistor R4 and install the desired surface-mount resistor (0805 case). Capacitor C5 (0805 case) must also be selected and installed. Refer to the MAX5035 data sheet's *Shutdown Mode* and *Undervoltage Lockout (UVLO)* sections to select values for resistor R4 and capacitor C5.

The MAX5035 EV kit's startup delay can also be utilized to sequence two MAX5035 EV kits. Components R4EVKIT1, R4EVKIT2, C5EVKIT1 and C5EVKIT2 determine the startup delay between the two EV kits. The following equation can be used to select values for R4 and C5:

$$C5 = \left( \frac{\text{Time\_delay}}{-R4 \times \ln \left( 1 - \frac{1.69V}{V_{\text{SHUT\_DOWN}}} \right)} \right)$$

where Time\_delay is the desired startup delay time, VSHUT\_DOWN is the desired startup voltage at the SHDN pad on the EV kit and 1.69V (typ) is the on/off threshold voltage of the MAX5035.

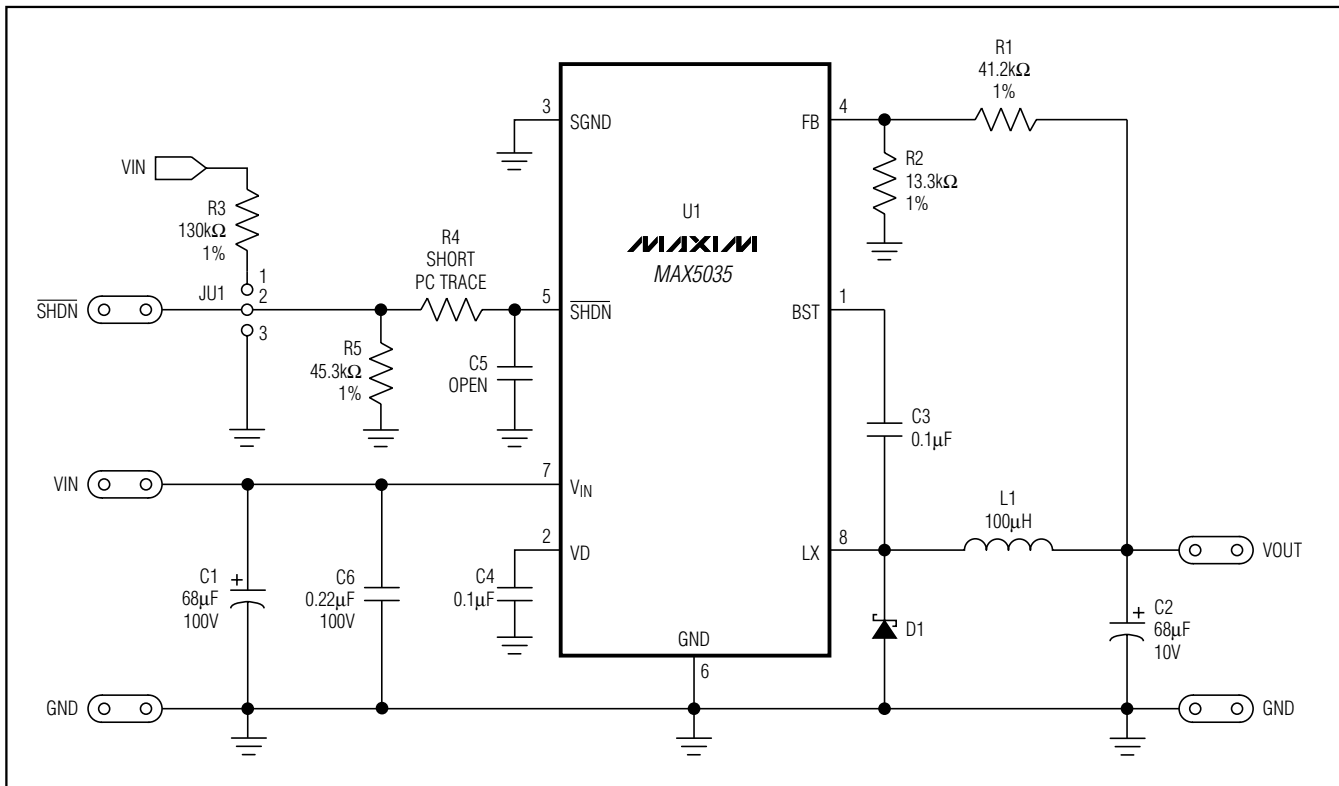

Figure 1. MAX5035 EV Kit Schematic

# MAX5035 Evaluation Kit

**Evaluates: MAX5035**

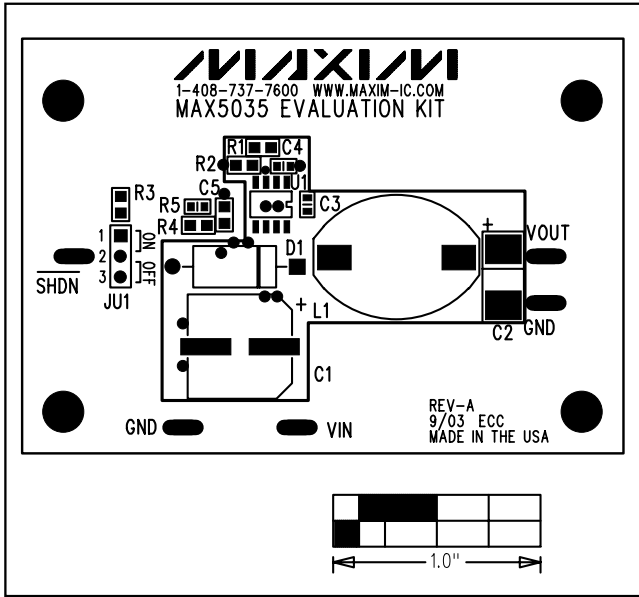

Figure 2. MAX5035 EV Kit Component Placement Guide—Component Side

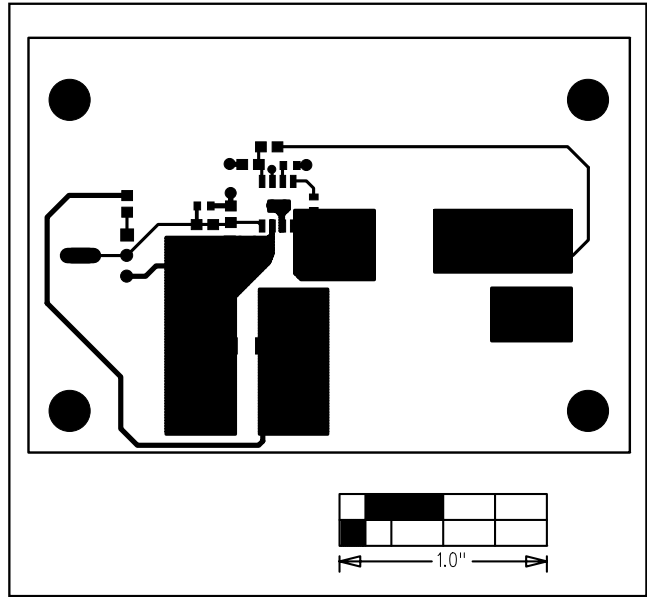

Figure 3. MAX5035 EV Kit PCB Layout—Component Side

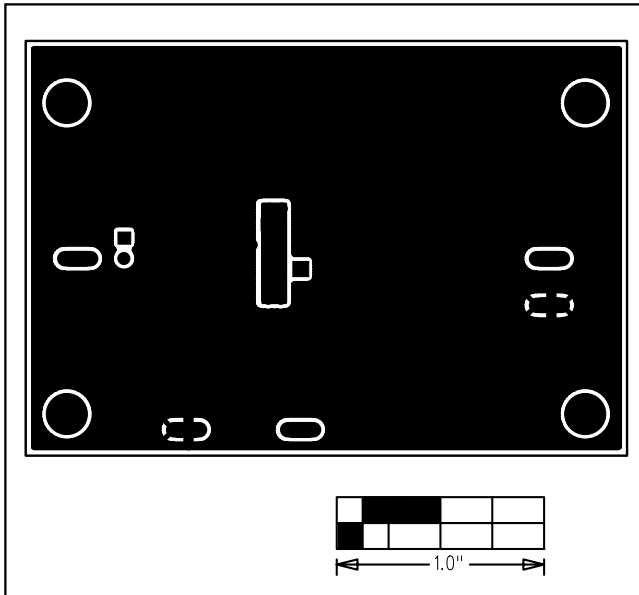

Figure 4. MAX5035 EV Kit PCB Layout—Solder Side

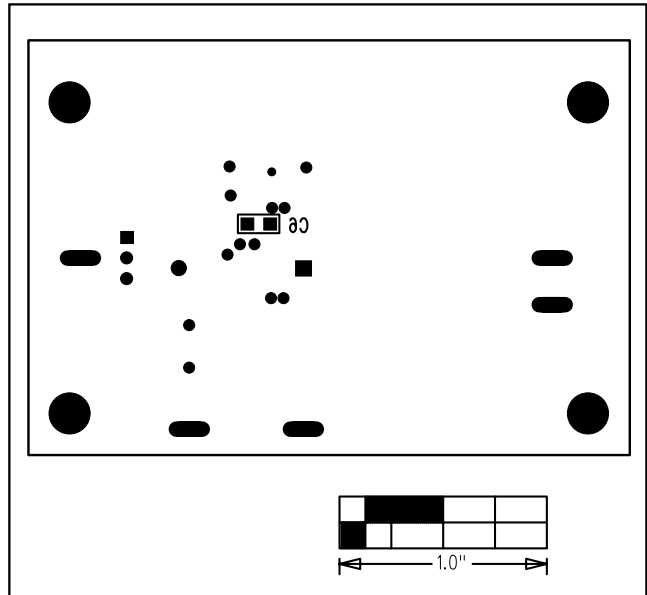

Figure 5. MAX5035 EV Kit Component Placement Guide—Solder Side

## Revision History

Pages changed at Rev 1: 1–4

Maxim cannot assume responsibility for use of any circuitry other than circuitry entirely embodied in a Maxim product. No circuit patent licenses are implied. Maxim reserves the right to change the circuitry and specifications without notice at any time.

4 \_\_\_\_\_ **Maxim Integrated Products, 120 San Gabriel Drive, Sunnyvale, CA 94086 408-737-7600**

© 2007 Maxim Integrated Products

**MAXIM** is a registered trademark of Maxim Integrated Products, Inc.